

Operator's manual

Electric hammer

EH

25, 65, 75



04.2011

0226245en / 003



Manufacturer

Wacker Neuson SE
Preußenstraße 41
80809 München
www.wackerneuson.com
Tel.: +49-(0)89-354 02-0
Fax: +49-(0)89-354 02-390

Translation of the original operator's manual in German



**WACKER
NEUSON**

1	Foreword	5
2	Introduction	6
2.1	Means of representation for this operator's manual	6
2.2	Wacker Neuson representative	7
2.3	Described machine parts.....	7
2.4	Identification of the machine.....	8
3	Safety	10
3.1	Principle.....	10
3.2	Qualification of the operating personnel.....	13
3.3	Protective gear	14
3.4	Transport.....	15
3.5	Operating safety	15
3.6	Safety during the operation of hand machines.....	18
3.7	Safety during the operation of electric appliances.....	18
3.8	Maintenance	20
4	Safety and information labels	21
5	Scope of delivery	22
6	Structure and function	23
6.1	Application.....	23
6.2	Functional description.....	23
7	Components and operator's controls	24
8	Transport	25
9	Use and operation	26
9.1	Prior to starting the machine.....	26
9.2	Changing tools.....	26
9.3	Starting up	28
9.4	Switching on the machine.....	29
9.5	Decommissioning	30
10	Maintenance	31
10.1	Maintenance personnel qualifications	31
10.2	Maintenance schedule.....	32
10.3	Maintenance work	32

11	Troubleshooting	35
12	Disposal	36
	12.1 Disposal of waste electrical and electronic equipment.....	36
13	Accessories	37
	13.1 Truck	37
14	Technical data	39
	14.1 EH 25	39
	14.2 EH 65	41
	14.3 EH 75	42
	14.4 Extension cable	44
15	Glossary	46
	EC Declaration of Conformity	49
	Certificate	51

1 Foreword

This operator's manual contains information and procedures for the safe operation and maintenance of your Wacker Neuson machine. In the interest of your own safety and to prevent accidents, you should carefully read through the safety information, familiarize yourself with it and observe it at all times.

This operator's manual is not a manual for extensive maintenance and repair work. Such work should be carried out by Wacker Neuson service or authorized specialists.

The safety of the operator was one of the most important aspects taken into consideration when this machine was designed. Nevertheless, improper use or incorrect maintenance can pose a risk. Please operate and maintain your Wacker Neuson machine in accordance with the instructions in this operator's manual. Your reward will be troublefree operation and a high degree of availability.

Defective machine parts must be replaced immediately!

Please contact your Wacker Neuson representative if you have any questions concerning operation or maintenance.

All rights reserved, especially reproduction and distribution rights.

Copyright 2011 Wacker Neuson SE

No part of this publication may be reproduced in any form or by any means, electronic or mechanical, including photocopying, without the expressed written permission of Wacker Neuson.

Any type of reproduction, distribution or storage on data media of any type and form not authorized by Wacker Neuson represents an infringement of copyright and will be prosecuted.

We expressly reserve the right to make technical modifications – even without special notice – which aim at further improving our machines or their safety standards.

2 Introduction

2.1 Means of representation for this operator's manual

Warning symbols

This operator's manual contains safety information of the categories: DANGER, WARNING, CAUTION, NOTICE.

They should be followed to prevent danger to life and limb of the operator or damage to equipment and exclude improper service.



DANGER

This warning notice indicates immediate hazards that result in serious injury or even death.

- ▶ Danger can be avoided by the following the actions mentioned.
-



WARNING

This warning notice indicates possible hazards that can result in serious injury or even death.

- ▶ Danger can be avoided by the following the actions mentioned.
-



CAUTION

This warning notice indicates possible hazards that can result in minor injury.

- ▶ Danger can be avoided by the following the actions mentioned.
-

NOTICE

This warning notice indicates possible hazards that can result in material damage.

- ▶ Danger can be avoided by the following the actions mentioned.
-

Notes

Note: Complementary information will be displayed here.

Instructions

- ▶ This symbol indicates there is something for you to do.
- 1. Numbered instructions indicate that you have to carry out something in a defined sequence.
- This symbol is used for lists.

2.2 Wacker Neuson representative

Depending on your country, your Wacker Neuson representative is your Wacker Neuson service, your Wacker Neuson affiliate or your Wacker Neuson dealer.

You can find the addresses in the Internet at www.wackerneuson.com.

The address of the manufacturer is located at the beginning of this operator's manual.

2.3 Described machine parts

This operator's manual is valid for different machine parts from a product range. Therefore some figures can differ from the actual appearance of your machine. It is also possible that the descriptions include components which are not a part of your machine.

Details for the described machine types can be found in the chapter *Technical Data*.



2.4 Identification of the machine

Nameplate position

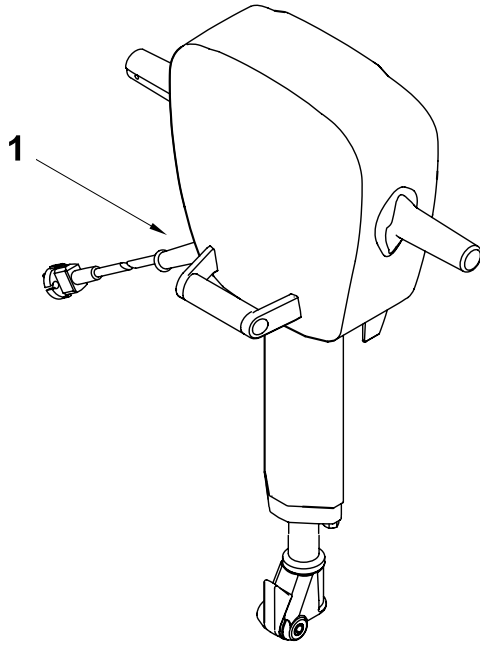

Item	Designation
1	Nameplate

Nameplate data

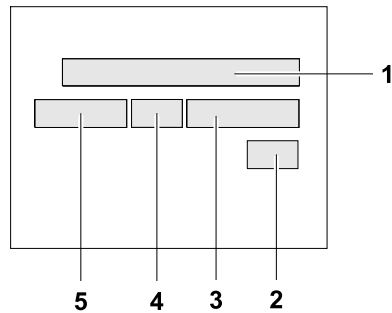

The nameplate lists information that uniquely identifies your machine. This information is needed to order spare parts and when requesting additional technical information.

► Enter the information of your machine into the following table:

Item	Designation	Your information
1	Group and type	
2	Construction year	
3	Machine no.	
4	Version no.	
5	Item no.	

3 Safety

3.1 Principle

State of the art

This machine has been constructed with state-of-the-art technology according to the recognized rules of safety. Nevertheless, when used improperly, dangers to the life and limb of the operator or to third persons or damage to the machine or other materials cannot be excluded.

Proper use

The machine must only be used for the following purposes:

- Breaking off concrete and asphalt and soil that is full of boulders.
- Breaking off concrete, masonry and other construction materials, untouched and frozen ground.
- Scarifying roads and concrete, asphalt, tar and wooden and stone paving.
- Cutting clay, loam, peat and salts.
- Breaking up compacted soils.
- Ramming in posts, probes and grounding rods.
- Tamping sleepers in track construction (only EH 22).

The machine may only be used with tools that are intended for use with the machine and the material being worked on.

The machine may not be used for the following purposes:

- Working on hazardous materials such as asbestos.

Its proper use also includes the observance of all instructions contained in this operator's manual as well as complying with the required service and maintenance instructions.

Any other use is regarded as improper. Any damage resulting from improper use will void the warranty and the liability on behalf of the manufacturer. The operator assumes full responsibility.



Structural modifications

Never attempt to modify the machine without the written permission of the manufacturer. To do so will endanger your safety and the safety of other people! In addition, this will void the warranty and the liability on behalf of the manufacturer.

Especially the following are cases of structural modifications:

- Opening the machine and the permanent removal of components from Wacker Neuson.
- Installing new components which are not from Wacker Neuson and not equivalent to the original parts in design and quality.
- Installation of accessories which are not from Wacker Neuson.

It is no problem to install spare parts from Wacker Neuson.

It is no problem to install accessories that are available in the Wacker Neuson product range of your machine. Please refer to the installation regulations in this operator's manual.

Do not drill into the housing, e.g. to install signs. Water could penetrate the housing and damage the machine.

Requirements for operation

The ability to operate the machine safely requires:

- Proper transport, storage and setup.
- Careful operation.
- Careful service and maintenance.

Operation

Operate the machine only as intended and only when in proper working condition.

Operate the machine in a safety-conscious manner with all safety devices attached and enabled. Do not modify or disable any safety devices.

Before starting operation, check that all control and safety devices are functioning properly.

Never operate the machine in a potentially explosive environment.

Maintenance

Regular maintenance work is required in order for the machine to operate properly and reliably over time. Failure to perform adequate maintenance reduces the safety of the machine.

- Strictly observe the prescribed maintenance intervals.
- Do not use the machine if it requires maintenance or repairs.

Malfunctions

If you detect a malfunction, you must shut down and secure the machine immediately.

Eliminate the malfunctions that impair safety immediately!

Have damaged or defective components replaced immediately!

For further information, refer to chapter *Troubleshooting*.

Spare parts, accessories

Use only spare parts from Wacker Neuson or such that are equivalent to the original parts in design and quality.

Only use accessories from Wacker Neuson.

Non-compliance will exempt the manufacturer from all liability.

Exclusion of liability

Wacker Neuson will refuse to accept liability for injuries to persons or for damage to materials in the following cases:

- Structural modifications.
- Improper use.
- Failure to comply with this operator's manual.
- Improper handling.
- Using of spare parts which are not from Wacker Neuson and not equivalent to the original parts in design and quality.
- Using of accessories which are not from Wacker Neuson.

Operator's manual

Always keep the operator's manual near the machine or near the worksite for quick reference.

If you have misplaced the operator's manual or require an additional copy, contact your Wacker Neuson representative or download the operator's manual from the Internet (www.wackerneuson.com).

Always hand over this operator's manual to other operators or to the future owner of the machine.

Country-specific regulations

Observe the country-specific regulations, standards and guidelines in reference to accident prevention and environmental safety, for example those pertaining to hazardous materials and wearing protective gear.

Complement the operator's manual with additional instructions taking into account the operational, regulatory, national or generally applicable safety guidelines.

Operator's controls

Always keep the operator's controls of the machine dry, clean and free of oil or grease.

Operating elements such as ON/OFF switch, gas handles etc. may not be locked, manipulated or changed without authorization.

Checking for signs of damage

Inspect the machine when it is switched off for any signs of damage at least once per work shift.

Do not operate the machine if there is visible damage or defects.

Have any damage or defects eliminated immediately.

3.2 Qualification of the operating personnel

Operator qualifications

Only trained personnel are permitted to start and operate the machine. The following rules also apply:

- You are physically and mentally fit.
- You have received instruction on how to independently operate the machine.
- You have received instruction in the proper use of the machine.
- You are familiar with required safety devices.
- You are authorized to start machines and systems in accordance with the standards governing safety.
- Your company or the operator has assigned you to work independently with this machine.

Incorrect operation

Incorrect operation or misuse by untrained personnel can endanger the health and safety of the operator or third persons and also cause machine and material damage.



Operating company responsibilities

The operating company must make the operator's manual available to the operator and ensure that the operator has read and understood it.

Work recommendations

Please observe the recommendations below:

- Work only if you are in a good physical condition.
- Work attentively, particularly as you finish.
- Do not operate the machine when you are tired.
- Carry out all work calmly, circumspectly and carefully.
- Never operate the machine under the influence of alcohol, drugs or medication. This can impair your vision, reactions and your judgment.
- Work in a manner that does not endanger others.
- Ensure that no persons or animals are within the danger zone.

3.3 Protective gear

Work clothing

Clothing should be appropriate, i.e. should be close-fitting but not restrict your movement.

When on construction sites, do not wear long hair loosely, loose clothing or jewelry including rings. These objects can easily get caught or be drawn in by moving machine parts.

Only wear clothing made of material that is not easily flammable.

Personal protective gear

Wear personal protective gear to avoid injuries or health hazards:

- Non-skid, hard-toed shoes.
- Work gloves made of durable material.
- Overalls made of durable material.
- Hard hat.
- Ear protection.
- Face protection.
- Eye protection.
- Breathing protection in the case of dusty ambient air.

Ear protection

This machine generates noise that exceeds the country-specific permissible noise levels (individual rating level). It may therefore be necessary to wear ear protection. You can find the exact value in the chapter *Technical Data*.

When wearing ear protection while working, you must pay attention and exercise caution because your hearing is limited, e.g. in case someone screams or a signal tone sounds.

Wacker Neuson recommends that you always wear ear protection.

3.4 Transport

Switching off the machine

Before you transport the machine, switch it off and pull the plug out of the plug receptacle. Allow the motor to cool down.

Transporting the machine

Secure the machine on the transport device against tilting, falling or slipping.

Lifting the machine

A falling machine can cause serious injuries.

The machine has no lifting or lashing points.

When lifting the machine, secure it in a closed transport container or similar in order to prevent it from toppling, falling or slipping away.

Restarting

Machines, machine parts, accessories or tools that were detached for transport purposes must be re-mounted and fastened before restarting.

Only operate in accordance with the operating instructions.

3.5 Operating safety

Explosible environment

Never operate the machine in a potentially explosive environment.



Work environment

Familiarize yourself with your work environment before you start work. This includes e.g. the following items:

- Obstacles in the work and traffic area.
- Load-bearing capacity of the ground.
- The measures needed to cordon off the construction site from public traffic in particular.
- The measures needed to secure walls and ceilings.
- Options available in the event of an accident.

Safety in the work area

When working with the machine especially pay attention to the following points:

- Electric lines or pipes in work area.
- Gas lines or water lines in the work area.
- Material becoming separated, dropping down or ejected. Make sure that you do not put other persons in danger.
- Pay maximum attention in the vicinity of drops or slopes. Risk of falling.
- Maintain a sufficient distance from flammable materials.

Checks before starting work

Check the following points before beginning work:

- Condition of tools.
- Machine settings.
- Connection value of the machine.

Starting the machine

Observe the safety information and warning notices located on the machine and in the operator's manual.

Never attempt to start a machine that requires maintenance or repairs.

Start the machine as described in the operator's manual.

Vertical stability

Always make sure that you stand firmly when working with the machine. This applies particularly when working on scaffoldings, ladders, uneven or slippery floors etc.

Caution with hot parts

Do not touch any hot parts such as tools or tool holders during operation or directly afterwards. These parts can become very hot and can cause severe burns.

Caution with movable parts

Keep your hands, feet and loose clothing away from moving or rotating machine parts. Parts of your body being pulled in or crushed can cause serious injuries.

Caution with toxic materials

Some materials may contain toxic chemicals which are released during demolition. Therefore personal protective equipment must be worn to prevent inhalation of and skin contact with work dust.

Do not direct towards people

Do not direct the machine towards people in the vicinity during operation. The tool might be flung out and cause serious injuries.

No persons endangered

Be sure that no persons are endangered by flying or falling materials. Always work very attentively, and anticipate potential hazards.

Switching off the machine

Switch off the machine and pull the plug out of the plug receptacle in the following situations:

- Before breaks.
- If you are not using the machine.
- If you are changing the tool.
- If you are removing chips or splinters.

Before storing the machine, wait until it has completely stopped running.

Store the machine or put it down in such a way that it cannot tilt, fall down or slip.

Storage

Set the machine down or store it securely so that it cannot tilt, fall down or slip.

Storage location

After operation, allow the machine to cool and then store it in a sealed-off, clean and dry location protected against frost and inaccessible to children.



3.6 Safety during the operation of hand machines

Safe working with hand machines

Secure loose workpieces with suitable methods.

While working, as a rule hold the machine on the provided handles with both hands.

While working, hold the machine in such a way that hand injuries are avoided when hitting hard objects.

Setting the hand machine down properly

Set the machine down carefully. Do not drop the machine to the floor or from greater heights. Dropping the machine can cause injuries to other persons or the machine itself can be damaged.

Safe working with the hammer

Keep the tool holder closed during operation.

Guide the power cable always from the machine to the rear and keep the power cable away from the working range of the machine.

3.7 Safety during the operation of electric appliances

Specific regulations for electrical appliances

Observe the safety information provided in the brochure *General Safety Rules* which is included in the scope of delivery of your machine.

Also observe the country-specific regulations, standards and guidelines in reference to accident prevention in connection with electrical equipment and machines.

⚠ WARNING Read all safety information and instructions. Failure to follow the safety information and instructions may result in electric shock, fire and/or serious injury.

Save all safety information and instructions for future reference.

Electric power supply for electrical appliances of class rating II

Note: The rated voltage is indicated on the nameplate of your machine.

The machine may only be connected to an electric power supply with all machine parts in proper working condition. Take special notice of the following components:

- Plug.
- Power cable over the entire length.
- Switch diaphragm of the ON/OFF switch, if there is one.
- Plug receptacles.

Electrical appliances of class rating II have a strengthened or double insulation (protective insulation). They have no connection to the grounded conductor.

There must be at least one of the following safety devices if connected to a stationary or mobile generator:

- Fault current protective switch.
- Isolation (earth leakage) monitor.
- IT-net.

Note: Observe the respective national safety regulations!

Extension cable

The machine may only be operated with undamaged and tested extension cables!

Only use extension cables with grounded conductor and correct connection of the grounded conductor to the plug and coupling (only for machines of class rating I, see chapter *Technical data*).

Only use tested extension cables which are suitable for use at construction sites: Average rubber hose H05RN-F or better – Wacker Neuson recommends H07RN-F, an SOW cable, or a country-specific equivalent design.

Immediately replace damaged extension cables (e.g. tears in the sheathing) or loose plugs and couplings.

Cable drums and multiple plug receptacles must fulfill the same requirements as the extension cable.

Protect extension cables, multiple plug receptacles, cable drums and connection couplings against rain, snow or any other forms of moisture.

Uncoil the cable drum completely

Danger of fire due to wound cable drum.

Uncoil the cable drum completely before operation.

Protecting the power cable

Do not use the power cable to pull or lift the machine.

Do not unplug the power cable by pulling on the cable.

Protect the power cable from heat, oil and sharp edges.

If the power cable is damaged or the plug is loose, have it replaced immediately by your Wacker Neuson representative.

Protecting from moisture

Protect the machine against rain, snow or any other forms of moisture. This could cause damage or other malfunctions.

3.8 Maintenance

Maintenance work

Service and maintenance work must only be carried out to the extent described in these operating instructions. All other procedures must be performed by your Wacker Neuson representative.

For further information, refer to chapter *Maintenance*.

Disconnecting the machine from the electric power supply

Before carrying out service or maintenance work, pull the plug out of the plug receptacle in order to disconnect the machine from the electric power supply.

Cleaning

Always keep the machine clean and be sure to clean it each time you have finished using it.

Do not use gasoline or solvents. Danger of explosion!

Do not use high pressure washers. Permeating water can damage the machine. When electrical equipment is present, this can pose a serious injury risk from electric shocks.





4 Safety and information labels

Your machine has adhesive labels containing the most important instructions and safety information.

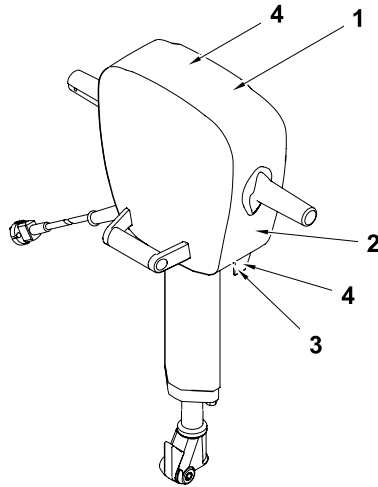
- Make sure that all the labels are kept legible.
- Replace any missing or illegible labels.

The item numbers for the labels are in the parts book.



Item	Label	Description
1		Wear personal protective gear to avoid injuries or health hazards: <ul style="list-style-type: none"> ■ Ear protection. ■ Eye protection. Read the operator's manual before start-up.
2	without US machines 	Guaranteed sound power level.
3		Caution. Warning of hot surface.
4	US machines 	Warning.

5 Scope of delivery

The scope of delivery includes:

- Machine.
- Operator's manual.
- Parts book.
- General safety information.

6 Structure and function

6.1 Application

Use the machine only as intended, see chapter *Safety, Proper use*.

6.2 Functional description

Principle

The machine is a demolition hammer with a pneumatic percussion system.

It is driven by an electric motor.

The rotary movement of the drive engine is converted into a stroke movement via a transmission and a crank gear.

The piston is moved forwards and backwards by the crank gear, this compresses the air (forward movement) or generates a partial vacuum (backward movement). Due to change in pressure the percussion piston is moved forward and backwards (air cushion percussion system) and hits the tool.



7 Components and operator's controls

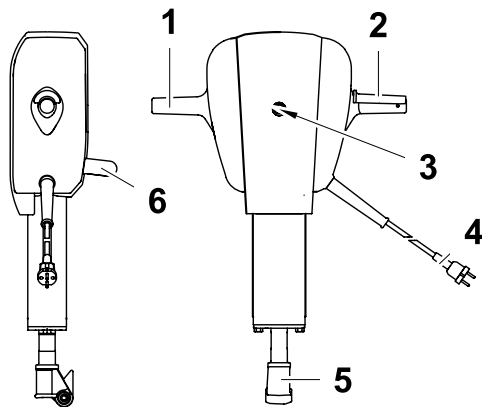

Item	Designation	Item	Designation
1	Handle	4	Power cable with plug
2	ON/OFF switch	5	Tool holder
3	Zerk fitting	6	Supplementary handle

Tool holder

The tool holder is used to hold the tool.

Supplementary handle

The supplementary handle simplifies working in a tilted position.

Wacker Neuson recommends to carry the machine using the supplementary handle.

8 Transport



WARNING

Improper handling can result in injury or serious material damage.

- ▶ Read and follow all safety information of this operator's manual, see chapter *Safety*.
-

Performing preparations

1. Pull the plug from the plug receptacle.
2. Let machine cool off.
3. Remove tool.
4. Wind up the power cable.

Transporting the machine

5. Lift machine with the supplementary handle.
6. Place the machine on or into a suitable transport vehicle.
7. Secure the machine against falling over and down or sliding.

Note: Wacker Neuson recommends to use the truck for the transport on the construction site, refer to chapter *Accessories*.



9 Use and operation



WARNING

Improper handling can result in injury or serious material damage.

- ▶ Read and follow all safety information of this operator's manual, see chapter *Safety*.
-



WARNING

Electrical voltage.

Injuries from electrocution.

- ▶ Remove the plug from the plug receptacle before all work on the machine.
-

9.1 Prior to starting the machine

After unpacking, the machine is ready for operation.

Checking the machine

- ▶ Check the machine and all components for damages.

Checking the mains

- ▶ Check if mains or power distribution on the construction site have the correct operating voltage (see nameplate of the machine or chapter *Technical Data*).
- ▶ Check if mains or power distribution on the constructions site are protected in accordance with current standards and regulations.

9.2 Changing tools

General notes

You can change the tool without additional tools.

Notes on using tools

Only use tools with the following properties:

- The tool must be suitable for the tool holder.
- The tool end must be undamaged.
- The tool must be sufficiently sharp to avoid impact damage.
- The tool must be suitable for the intended application.

Inserting tool

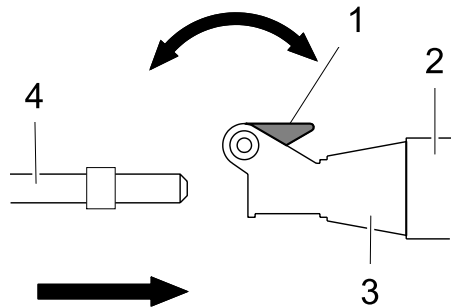

Item	Designation	Item	Designation
1	Handle	3	Tool holder
2	Guide cylinder	4	Tool

1. Clean tool end.
2. Swivel out handle on the tool holder.
3. Turn the tool into the position which is most suitable for the intended work.
4. Push tool into the tool holder as far as it will go.
5. Press the handle on the tool holder.
6. Check to see if the tool is locked by pulling on the tool.

Removing tool

**CAUTION**

Risk of burn injury from a hot tool and guide cylinder.

- ▶ Touch the tool only if you are wearing protective gloves.

1. Swivel out handle on the tool holder.
2. Remove tool from the tool holder.
3. Press the handle on the tool holder.

9.3 Starting up

Connecting the machine to the electric power supply

The machine may only be connected to AC single phase, connection values see chapter *Technical Data*.

NOTICE

Electrical voltage.

Incorrect voltage can cause damage on the machine.

- ▶ Check if the voltage of the current source corresponds with the information of the machine, see chapter *Technical Data*.



WARNING

Electrical voltage.

Injuries from electrocution.

- ▶ Check power cable and extension cable for signs of damage.
- ▶ Only use extension cables for which grounded conductors are connected to the plug and the coupling (only for machines of class rating I).

-
1. If required, connect the machine to a permitted extension cable.

Note: See chapter *Technical data* for the permitted lengths and cross-section areas of extension cables.

2. Insert the plug into the plug receptacle.

Work tips

- When working, use the weight of the hammers.
- Pressing forcefully against the material to be worked on does not improve the machine's performance.
- Press the machine against the material to be worked as follows:
 - Apply at least 100 N pressure.
 - Press with sufficient strength that the machine noticeably locks into place.
 - Apply somewhat less pressure as soon as you feel the lower stop.

9.4 Switching on the machine

Processing material



WARNING

Injuries from insufficiently guided or uncontrolled machine.

- ▶ Always hold machine with both hands and stand firmly.

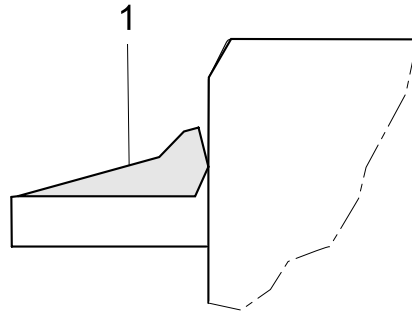

Item	Designation
1	ON/OFF switch

1. Hold the machine firmly with both hands.
2. Place the tool into position on the material.
3. Press down the ON/OFF switch.
4. With both hands, press the machine against the material to be processed.

Note: Press with sufficient strength that you feel the machine's spring system, but not the lower stop.

5. When the material has been processed, lift and adjust the machine.

Note: Proceed as follows if the tool gets stuck in the material:

- Open the tool holder and remove the tool.
- Continue working with another tool.

Note for breaking off edges

Pay attention to the following points when breaking off edges:

- Vertical stability.

9.5 Decommissioning

Switching off the machine

1. Release ON/OFF switch.
2. Wait until the machine has come to a complete standstill.
3. Set down the machine in such a way that it cannot tilt, fall or slip.
4. Pull the plug from the plug receptacle.

10 Maintenance



WARNING

Improper handling can result in injury or serious material damage.

- ▶ Read and follow all safety information of this operator's manual, see chapter *Safety*.
-

10.1 Maintenance personnel qualifications

Qualifications for maintenance work

The maintenance work described in this operator's manual may be performed by any responsible user unless otherwise stated.

Some maintenance work may only be performed by specially trained personnel or by the service staff of your Wacker Neuson contact — these are specifically noted.



10 Maintenance

10.2 Maintenance schedule

Task	Daily before operation	Every 20 hrs.	Monthly
Check power cable for perfect condition – if power cable is defective, have it replaced. *	■		
Visual inspection of all parts for damage.	■		
Clean the machine. ■ Ventilation slots.	■		
Check the tool end and cutting edge – if required, sharpen, reforge or replace (have it replaced).	■		
Lubricate the machine.		■	
Check tool holder for wear – have it changed, if necessary. *			■

* Have these tasks carried out by the service department of your Wacker Neuson contact person.

10.3 Maintenance work



WARNING

Electrical voltage.
Injuries from electrocution.

- ▶ Remove the plug from the plug receptacle before all work on the machine.
-

Working in the workshop

Perform maintenance work in a workshop on a workbench. This has the following benefits:

- Protection of the machine of contamination on the construction site.
- A level and clean work surface makes work easier.
- There is a better overview over small parts and they are not lost as easily.

10.3.1 Visual inspection for damage



WARNING

A damaged machine part or power cable can result in personal injury caused by electric current.

- ▶ Do not operate a damaged machine.
 - ▶ Have a damaged machine repaired immediately.
-

- ▶ Check all machine parts and components for damage.

10.3.2 Cleaning machine

Clean the machine after use.

1. Clean the ventilation slots with a suitable non-metallic tool.
2. Wipe the housing with a damp and clean cloth.



10.3.3 Lubricating the machine

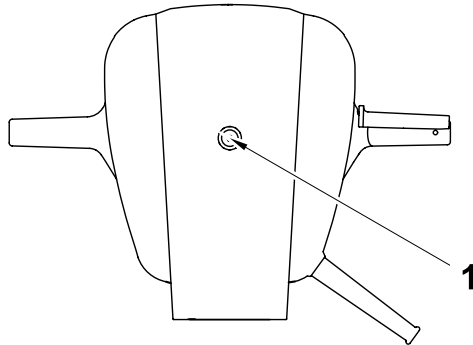

Item	Designation
1	Zerk fitting

1. Remove any dirt around the zerk fitting.
2. Place filled manual grease gun onto the zerk fitting and operate approx. 20 times.

Note: Only use special lubricants for lubricating, see chapter *Technical Data*.

3. Wipe the area around the zerk fitting with a clean cloth.

10.3.4 Checking the tool holder for wear

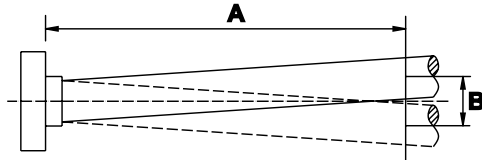

Item	Value
A	200 mm
B	Max. 6 mm

1. Insert the tool.
Note: Use a new tool to measure only the wear of the tool holder and not the wear of the tool.
 2. Measure the tool play 200 mm from insertion point.
Play may not exceed 6 mm.
- If the play exceeds 6 mm, the tool holder must be replaced.

11 Troubleshooting

Potential faults, their causes and remedies can be found in the following table.

Notify your Wacker Neuson contact in case of malfunctions you cannot or may not remedy yourself.

Malfunction	Cause	Remedy
Machine not in operation.	Power cable is interrupted.	Check power cable, have it replaced if defective. *
	Machine has switched off due to excess temperature.	Let machine cool off.

* Have these tasks carried out by the service department of your Wacker Neuson contact person.



12 Disposal

12.1 Disposal of waste electrical and electronic equipment

For customers in EU countries

This device is subject to the European Directive 2002/96/EC on waste electrical and electronic equipment (WEEE) and the corresponding national legislation. The WEEE directive outlines the procedure for handling electrical waste equipment across the EU.



The device is labelled with the symbol of a crossed out dustbin shown here. This means you may not dispose of it with normal household waste but in a separate environmentally-friendly waste collection.

This device is a professional electrical tool designed for commercial applications only (B2B device according to WEEE directive). Contrary to equipment used in most private households (B2C devices), in some EU countries such as Germany, this device may not be disposed of at a collection point in a public disposal facility (for example at public waste depots). In case of doubt, ask the sales outlet about the proper disposal procedure for B2B electrical equipment in your country and ensure you dispose of the device in accordance with the valid legal guidelines. Please also note any information in the sales contract and the general terms and conditions from the point of sales.

The proper disposal of this device prevents the occurrence of any negative effects on people or the environment, follows the specific procedures for handling harmful substances and enables valuable raw materials to be recycled.

For customers in non-EU countries

The proper disposal of this device prevents the occurrence of any negative effects on people or the environment, follows the specific procedures for handling harmful substances and enables valuable raw materials to be recycled. Therefore, we recommend that this device is disposed of in a separate, environmentally-friendly waste collection and not with normal household waste. In some cases, national legislation also stipulates the separate disposal of electric and electronic products. Please ensure you dispose of this device in accordance with the valid regulations in your country.

13 Accessories

There is a wide range of accessories available for the machine.

For more information on the individual accessories, visit the following website:
www.wackerneuson.com.

13.1 Truck

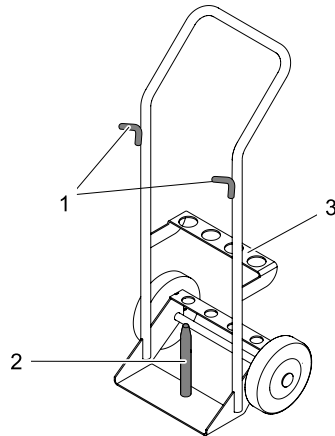

Item	Designation
1	Hanging device
2	Guide rod
3	Tool holder

Proper use

The truck must only be used for the transport of Wacker Neuson large hammers and the required tools.

The truck must not be used for the following:

- Transporting people.
- Transporting other machines except Wacker Neuson large hammers.

The truck must not be attached to vehicles.

Placing hammer on the truck



CAUTION

Insufficient stability of the truck.
Injury or damage caused by the truck tipping over or rolling off when the hammer is placed on it.

- ▶ Place truck on a level surface.
 - ▶ Secure truck against rolling off and tipping over.
-

1. Switch off the machine.
2. Remove tool from the tool holder.
3. Clean the truck's guide rod.
4. Insert hammer with the tool holder on the guide rod and rest on the handles of the truck.

Note: Do not crush the power cable at the handles.

5. Insert tool in the tool holder.

14 Technical data

14.1 EH 25

Designation	Unit	EH 25/230		
Item no.		0610330	0610395	0610397
Length x Width x Height (without tool)	mm (ft)	850 x 590 x 238 (2.8 x 1.9 x 0.8)	863 x 590 x 238 (2.8 x 1.9 x 0.8)	905 x 590 x 238 (3.0 x 1.9 x 0.8)
Weight	kg (lb)	25 (55)		26 (57)
Rated voltage	V	230 1~		
Rated frequency	Hz	50		
Rated power consumption	kW	2,5		
Rated current consumption	A	15.3		
Percussion rate	rpm	1275		
Single stroke energy	J	70		
Tool holder		∅ 27x80	hex 25x108	hex 28x152
Special lubricating grease		Retinax LX2 grease		
Drive		Three-phase AC motor		
Class rating *		II		
Protection class **		IP2X		
Sound power level L_{WA} ***	dB(A)	107		
Sound pressure level L_{pA} at operator's station ****	dB(A)	99		
Total vibration value of the acceleration a_{hv} *****	m/s^2 (in/s^2)	5 (197)		
Uncertainty of measurement of the vibration total value of the acceleration a_{hv}	m/s^2 (in/s^2)	0,5 (20)		

* According to DIN EN 61140.

** According to DIN EN 60529.

*** According to DIN EN ISO 3744.

14 Technical data

****According to DIN EN ISO 11201.

*****Determined according to DIN EN ISO 5349.

Designation	Unit	EH 25/230	
Item no.		0610396	0610404
Length x Width x Height (without tool)	mm (ft)	905 x 590 x 238 (3.0 x 1.9 x 0.8)	
Weight	kg (lb)	26 (57)	
Rated voltage	V	230 1~	
Rated frequency	Hz	50	
Rated power consumption	kW	2,5	
Rated current consumption	A	15.3	
Percussion rate	rpm	1275	
Single stroke energy	J	70	
Tool holder		hex 28x160	hex 32x160
Special lubricating grease		Retinax LX2 grease	
Drive		Three-phase AC motor	
Class rating *		II	
Protection class **		IP2X	
Sound power level L_{WA} ***	dB(A)	107	
Sound pressure level L_{pA} at operator's station ****	dB(A)	99	
Total vibration value of the acceleration a_{hv} *****	m/s^2 (in/s^2)	5 (197)	
Uncertainty of measurement of the vibration total value of the acceleration ahv	m/s^2 (in/s^2)	0,5 (20)	

* According to DIN EN 61140.

** According to DIN EN 60529.

*** According to DIN EN ISO 3744.

****According to DIN EN ISO 11201.



*****Determined according to DIN EN ISO 5349.

14.2 EH 65

Designation	Unit	EH 65/120
Item no.		0610421
Length x Width x Height (without tool)	mm (ft)	905 x 590 x 238 (3.0 x 1.9 x 0.8)
Weight	kg (lb)	26 (57)
Rated voltage	V	120 1~
Rated frequency	Hz	60
Rated power consumption	kW	1,9
Rated current consumption	A	15
Percussion rate	rpm	1060
Single stroke energy	J	65
Tool holder		Hex 28x152
Special lubricating grease		Retinax LX2 grease
Drive		Three-phase AC motor
Class rating *		II
Protection class **		IP2X
Sound power level L_{WA} ***	dB(A)	107
Sound pressure level L_{pA} at operator's station ****	dB(A)	99
Total vibration value of the acceleration a_{hv} *****	m/s^2 (in/s^2)	5 (197)
Uncertainty of measurement of the vibration total value of the acceleration ahv	m/s^2 (in/s^2)	0,5 (20)

* According to DIN EN 61140.

** According to DIN EN 60529.

*** According to DIN EN ISO 3744.

14 Technical data

****According to DIN EN ISO 11201.

*****Determined according to DIN EN ISO 5349.

14.3 EH 75

Designation	Unit	EH 75/240
Item no.		0610294
Length x Width x Height (without tool)	mm (ft)	905 x 590 x 238 (3.0 x 1.9 x 0.8)
Weight	kg (lb)	26 (57)
Rated voltage	V	240 1~
Rated frequency	Hz	60
Rated power consumption	kW	2.5
Rated current consumption	A	14.7
Percussion rate	rpm	1275
Single stroke energy	J	75
Tool holder		Hex 28x152
Special lubricating grease		Retinax LX2 grease
Drive		Three-phase AC motor
Class rating *		II
Protection class **		IP2X
Sound power level L_{WA} ***	dB(A)	107
Sound pressure level L_{pA} at operator's station ****	dB(A)	99
Total vibration value of the acceleration a_{hv} *****	m/s^2 (in/s^2)	5 (197)
Uncertainty of measurement of the vibration total value of the acceleration ahv	m/s^2 (in/s^2)	0,5 (20)

* According to DIN EN 61140.

** According to DIN EN 60529.

*** According to DIN EN ISO 3744.

**** According to DIN EN ISO 11201.

***** Determined according to DIN EN ISO 5349.

14.4 Extension cable



WARNING

Electrical voltage.
Injuries from electrocution.

- ▶ Check power cable and extension cable for signs of damage.
- ▶ Only use extension cables for which grounded conductors are connected to the plug and the coupling (only for machines of class rating I, see chapter *Technical Data*).

- Only use permitted extension cables, see chapter *Safety*.
- Refer to the following table for the required cross-section area of the extension cable:

Note: Refer to the nameplate or the chapter *Technical data* (via the item number) for the type designation and voltage rating of your machine.

Machines	Voltage [V]	Extension [m]	Cross-section area of cable [mm ²]
EH 25/230	230 1~	≤ 20	1.5
		≤ 33	2.5
		≤ 52	4
		≤ 77	6

US-Machines

Machines	Voltage [V]	Extension [m]	Cross-section area of cable [mm ²]
EH 65/120	120 1~	≤ 21	1,5
		≤ 35	2,5
		≤ 55	4
		≤ 82	6

Machines	Voltage [V]	Extension [ft]	Cross-section area of cable [AWG]
EH 65/120	120 1~	–	16
		≤ 95	14
		≤ 149	12
		≤ 235	10

Machines	Voltage [V]	Extension [m]	Cross-section area of cable [mm ²]
EH 75/240	240 1~	≤ 21	1,5
		≤ 35	2,5
		≤ 56	4
		≤ 83	6

Machines	Voltage [V]	Extension [ft]	Cross-section area of cable [AWG]
EH 75/240	240 1~	–	16
		≤ 96	14
		≤ 152	12
		≤ 240	10

Example

You utilize an EH 25/230 and want to use an extension cable with a length of 30 m.

The machine has an input voltage of 230 V.

According to the table, the extension cable must feature a cross-section area of 2,5 mm².



15 Glossary

Class rating

The class rating according to DIN EN 61140 specifies the safety measures for electrical equipment to avoid electrocution. There are four class ratings:

Class rating	Meaning
0	No special protection apart from the basic insulation. No grounded conductor. Plug connection without grounded conductor contact.
I	Connection of all conductive housing components to the grounded conductor. Plug connection with grounded conductor contact.
II	Reinforced or double insulation (protective insulation). No connection to the grounded conductor. Plug connection without grounded conductor contact.
III	Machines are operated on protective low voltage (< 50 V). Connection to the grounded conductor is not necessary. Plug connection without grounded conductor contact.

Protection class IP

The protection class according to DIN EN 60529 indicates the suitability of electrical equipment for use in certain ambient conditions as well as the protection against risks.

The protection class is specified by an IP code according to DIN EN 60529.

Code	Meaning 1st number: Protection against touching hazardous parts. Protection against permeating foreign objects.
0	Not protected against contact. Not protected against foreign bodies.
1	Protected against contact with the back of the hand. Protected against large foreign objects with diameter > 50 mm (1.9 in).
2	Protected against contact with one finger. Protected against medium-sized foreign objects (diameter > 12.5 mm (0.5 in)).
3	Protected against touch with a tool (diameter > 2.5 mm (0.01 in)). Protected against small foreign objects with (diameter > 2.5 mm (0.01 in)).
4	Protected against touch with a wire (diameter > 1 mm (0.03 in)). Protected against granular foreign objects (diameter > 1 mm (0.03 in)).
5	Protected against contact. Protected against dust depositing inside.
6	Completely protected against any contact. Protected from dust.

Code	Meaning 2nd number: Protection against permeating water
0	Not protected against permeating water.
1	Protected against water dropping vertically.
2	Protected against diagonally falling water (15° angle).
3	Protected against spray (60° angle).
4	Protected against spraying water from all directions.
5	Protected against water jets (nozzle) from any angle.
6	Protected against strong water jets (overflow).
7	Protected from temporary immersion in water.
8	Protected from ongoing immersion in water.



EC Declaration of Conformity

Manufacturer

Wacker Neuson SE
Preußenstraße 41,
80809 München

Product

Type		EH 25/230	
Product type		Demolition hammer	
Item no.		0610330, 0610395	0610397, 0610396, 0610404
Weight	kg	25 (55)	26 (57)
Measured sound power level	dB(A)	107	
Guaranteed sound power level	dB(A)	107	

Conformity assessment procedure in accordance with 2000/14/EC, Appendix VIII, 2005/88/EC, at the following test center:

VDE Prüf- und Zertifizierungsinstitut, Merianstraße 28, 63069 Offenbach/Main

Guidelines and standards

This is to certify that this product meets and complies with the relevant regulations and requirements of the following guidelines and standards:

2006/42/EC,

2006/95/EC, 2000/14/EC, 2005/88/EC, 2004/108/EC, EN 61000, EN 55014

Authorized representative for technical documentation: Axel Häret

Munich, 01/04/2010

Franz Beierlein
Head of product management

Dr. Michael Fischer
Head of Research and



AUTHORIZATION TO MARK

This authorizes the application of the Certification Mark(s) shown below to the models described in the Product(s) Covered section when made in accordance with the conditions set forth in the Certification Agreement and Listing Report. This authorization also applies to multiple listee model(s) identified on the correlation page of the Listing Report.

This document is the property of Intertek Testing Services and is not transferable. The certification mark(s) may be applied only at the location of the Party Authorized To Apply Mark.

Applicant: Wacker Neuson SE
Address: Preußenstr. 41
80809 München
Country: Germany

Manufacturer: Wacker Neuson SE
Address: Münchner Straße 31
85084 Reichertshofen
Country: Germany

Party Authorized To Apply Mark: Same as Manufacturer
Report Issuing Office: Intertek, Kaufbeuren, Germany

Control Number: 4002577

Authorized by: 
Ulla-Pia Johansson-Nilsson for
William T. Starr, Certification Manager



This document supersedes all previous Authorizations to Mark for the noted Report Number.

This Authorization to Mark is for the exclusive use of Intertek's Client and is provided pursuant to the Certification agreement between Intertek and its Client. Intertek's responsibility and liability are limited to the terms and conditions of the agreement. Intertek assumes no liability to any party, other than to the Client in accordance with the agreement, for any loss, expense or damage occasioned by the use of this Authorization to Mark. Only the Client is authorized to permit copying or distribution of this Authorization to Mark and then only in its entirety. Use of Intertek's Certification mark is restricted to the conditions laid out in the agreement and in this Authorization to Mark. Any further use of the Intertek name for the sale or advertisement of the tested material, product or service must first be approved in writing by Intertek. Initial Factory Assessments and Follow up Services are for the purpose of assuring appropriate usage of the Certification mark in accordance with the agreement, they are not for the purposes of production quality control and do not relieve the Client of their obligations in this respect.

Intertek Testing Services NA Inc.
165 Main Street, Corland, NY 13045
Telephone 800-345-3851 or 607-753-6711 Fax 607-756-6699

Standard(s):	UL 60745-1 Issued:2007/07/31 Ed:4 UL Standard for Hand-Held Motor-Operated Electric Tools Safety Part 1: General Requirements;
	UL 60745-2-6: Issued:2004/03/26 Ed:2 UL Standard for Hand-Held Motor-Operated Electric Tools Safety Part 2-6: Particular Requirements for Hammers
	CSA C22.2#60745-1 Issued:2007/07/31 Ed:3 Hand-Held Motor-Operated Electric Tools Safety Part 1: General Requirements;
	CSA C22.2#60745-2-6: Issued:2004/03/01 Ed:2 (R2008) Hand-Held Motor-Operated Electric Tools Safety Part 2-6: Particular Requirements for Hammers; Amemdment 1 : 2009/03/13
Product:	electric hammer
Brand Name:	Wacker Neuson
Models:	EH 25/230, EH 65/120, EH75/240

MMB

